

122317

Saxby EvoX Standard Bulkhead

FEATURES

- 5 years (2 years + 3 years) extended warranty
- Matt white textured & opal PC finish
- Constructed from polycarbonate
- IP65
- IK08
- Removable & Hinged gear tray
- Product can be used as utility light without bezel
- Interchangeable bezels
- Plenty of space in the base for quick installation & wiring
- Removable push connector for easy wiring
- Click on MW, EM, DALI, 0-10V, Casambi accessories
- MW is 3-in-1: on/off, corridor, photocell
- EM kit is 2-in-1: manual test & self test
- Testing holes on the connector for Continuity and IR tests (Using GS38 probes)

SPEC DATA

Product Wattage:	6W/8.5W/10.5W/13W
Product Lumen:	840/1190/1470/1820
Lumen/W:	140
Kelvin:	3000/4000/6000K
Energy Rating:	D
Beam Angle:	110°
SDCM:	≤ 6
CRI:	≥ 80
Lifetime (Hours):	50000
Power Factor:	>0.7
LED Brand:	BMTC
Driver Type:	Constant Current 180mA
Inrush Current at Start Up:	9A
Driver Output Voltage:	50-70V DC
Product Voltage:	220-240V
Hertz:	50/60
Surge Protection (KV):	1.5
Operating Temp.:	-20 to 45 Degree
Product Weight (KG):	0.76
Terminal Block:	4-way fast fix
Class:	2

ACCESSORIES

- 122324, Saxby EvoX Bezel Plain - Matt Black
- 122325, Saxby EvoX Bezel Plain - Chrome
- 122326, Saxby EvoX Bezel Eyelid - Matt White
- 122327, Saxby EvoX Bezel Eyelid - Matt Black
- 122321, Saxby X-Series Sensor MW & Photocell
- 122322, Saxby EvoX EM Kit 2-in-1 Manual & Self Test
- 124291, Saxby X-Series DALI Driver
- 124292, Saxby X-Series 0-10V Driver
- 124293, Saxby X-Series Casambi Driver

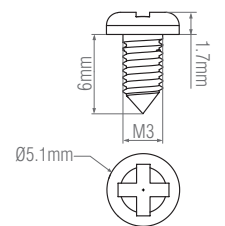
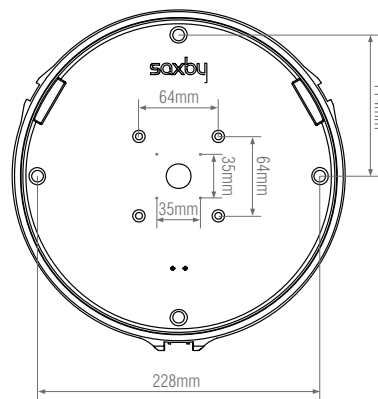
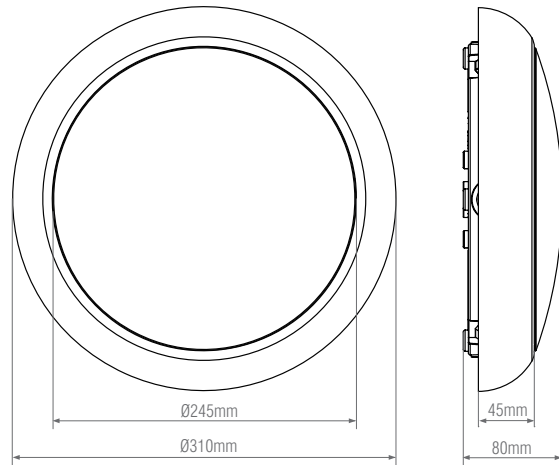

Screws included to lock up the diffuser